

The Grin Tech site is the authoritative source for V3 information. Please see the site for contemporary versions of this information.

Connector Pinout

The V3 CA device has a cable bundle bringing out all the signal wires into suitably terminated JST-SM plugs. The following shows the standard CA V3 wiring harness connector details for all cables coming out of the V3 CA:

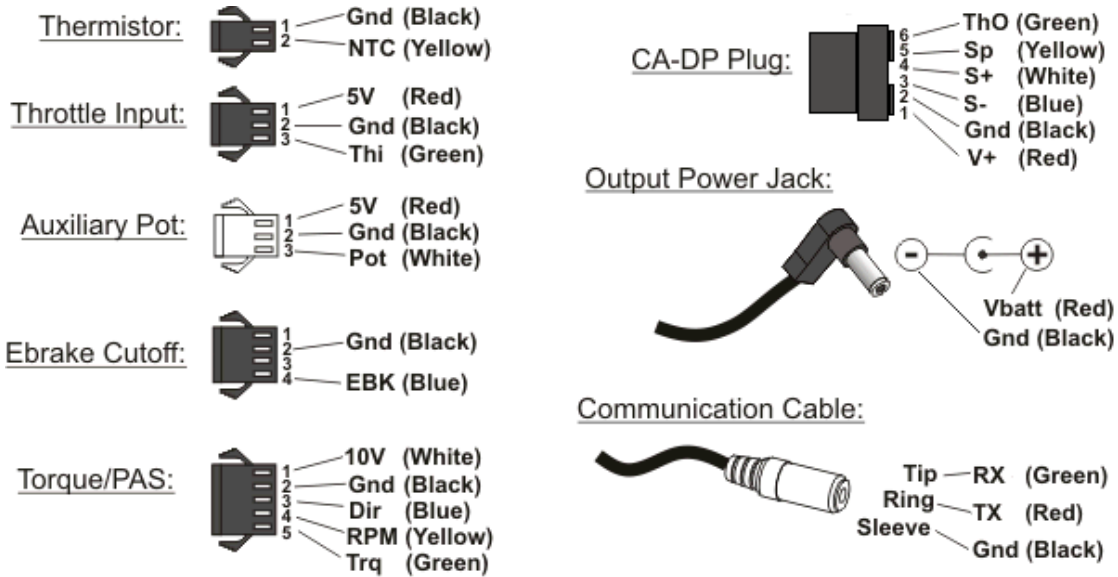

Pad Descriptions

The following shows the solder pad locations on the circuit board for anyone who is doing their own custom wiring harness directly into the Cycle Analyst enclosure:

