

PHOTON

User Manual

CYC MOTOR LTD
support@cycmotor.com



TABLE OF CONTENTS

SAFETY & PRECAUTION.....3

- General Safety 3
- Before the Ride..... 3
- Installation & Use 4
- Disclaimer..... 4
- Warning..... 5

TECHNICAL SPECIFICATIONS6

- Description 6
- General 6
- Parts List..... 7
- Dimensions..... 9
 - BSA Threaded 68/73/83mm Version..... 9
 - BSA Threaded 100mm Version 10
 - BSA Threaded 120mm Version 11
 - BB92 Version..... 12

INSTALLATION 13

- Required Tools 13
- Operating Notice 14
- Preparing Your Frame 14
- Mounting Options..... 14
- Warning..... 14
- Adjusting the Width of the Bottom Bracket 15
- Assembly Instruction..... 16
 - Spacer Information 19
- Wiring & Connection..... 20

MOBILE APP & DISPLAY 21

GENERAL MAINTENANCE22

- Torque Requirement for Bolts 23



WARRANTY..... 24

PURCHASES FROM A CYC DEALER 24

CONTACT INFORMATION..... 24

PRIVACY POLICY.....25

INFORMATION COLLECTION AND USE.....25



SAFETY & PRECAUTION

General Safety

Kindly read through the entire user manual. This manual contains important information to reduce user risk as well as instructions for this product's proper use. Do not discard the manual but keep it for reference.

Note that your personal safety remains your responsibility and that the user must contact CYCMOTOR LTD or their official product dealer/distributor directly for any further guidelines or assistance.

Never interfere with the movable parts when the drive unit is connected to a power supply. This could result in serious injury if the system is accidentally engaged.

This product is a powerful motor system that is dangerous for children and must be handled by an adult at all times. Small components and accessories may also present a choking hazard. Keep the motor system and accessories out of reach from children.

All components and accessories may only be replaced with identical components directly supplied by CYC MOTOR LTD or an official product dealer/distributor. CYC MOTOR LTD cannot be held liable for any damages as a result of using unapproved parts.

This product only complies with local, state, and federal regulations if speed limits are set accordingly. Ensure that you have set up your X1 Pro kit according to your local, state, and federal regulations when using and registering this drive unit on a public road/area.

Before the Ride

Ensure that the drive unit chain has the proper tension. Incorrect tension could cause jamming of the system and result in injury while riding. Inspect the chain tension regularly.

Ensure that the chains are properly lubricated. Cleaning and lubricating your chain with a regular bicycle chain cleaner, is advised regularly.

When plugging in your kit, please ensure that your peripherals are connected properly as faulty connection could result in damage of the controller or batteries.



Inspect all electrical wires and plugs for damage regularly.

Secure all wires properly. Ensure that the throttle can be twisted freely without friction and that the throttle can return to its original position without restriction. This is to prevent any uncontrolled response of the system.

Installation & Use

Do not install anything other than the parts and accessories that came with this drive unit. Doing so could damage the product.

The drive system can be activated and deactivated by holding down the ON/OFF button of the display.

Avoid changing the bike gear (note: this is different from the drive unit's assist level) while the drive unit is powering the bike. This may lead to excessive wear on the chain and chain rings or other gear related failure. When changing gears, use human input only. After the gear is changed, you may accelerate again with the throttle or continue using the PAS.

Take off with the appropriate assist level and bike gear.

This product is **splash proof** and **rain proof** but not waterproof. Do not submerge it underwater.

Disclaimer

If you require any more information or have any questions about the user manual disclaimer, please feel free to contact us via email at support@cycmotor.com or call +852-3690-8938.

All the information contained in this manual is published in good faith and for general informational purposes only. CYC MOTOR LTD does not make any warranties about the completeness of this information and encourages further inquiries if needed. CYC MOTOR LTD will not be held liable for any losses and/or damages in connection with the use of this product. **The use of this product is at own risk.**



Please contact CYC MOTOR LTD if you are unsure about the assembly instructions or for any further assistance as CYC MOTOR LTD will be held liable for any losses and/ or damages created by the assembly.

The control unit's hardware and software are under the GPL V3 open-source license. VESC® is a trademark of Benjamin Vedder. More information can be found at www.gnu.org/licenses/gpl-3.0.html. CYCMOTOR LTD's source code can be found at www.github.com/CYC-MOTOR. Different firmware can be loaded to this controller.

Warning

Any issues with this product's performance or damages sustained to the product as a result of loading unauthorized firmware, will not be supported, or warrantied by CYC MOTOR LTD or any authorised product dealer.

Modifications of any kind is not advised. Any issues with this product's performance or damages sustained to be the product as a result of modifications will not be supported or warrantied by CYC MOTOR LTD or any authorized product dealer. If the product or its components have been found to be modified, warranty of the product may be limited in the case where troubleshooting and/ or replacement may be needed.



TECHNICAL SPECIFICATIONS

Description

This product is a high-powered electric bike (ebike) drive unit kit which includes a programmed control unit and peripherals. This product is designed to be installed as a conversion system to convert standard bicycles into electric bicycles.

General

| | |
|---|--|
| Rated Voltage | 36V – 52V |
| Max. RPM at Crank | >300 RPM |
| Rated Power | 250W / 750W |
| Max. Torque at Crank | 110 N.m. |
| Colour | Anodized Black |
| Weight of Motor Uni | 3.2 kg |
| Total Weight with Crank set & BB | 4.5 kg |
| Bracket Materials | 7075-T6 |
| Crank Arm Length | 165mm or 175mm |
| Control Method | FOC |
| Motor Sensor | Hall & Temp. Sensor |
| Chain ring | 34T / 38T / 42T / 50T |
| Compatibility | 68-83mm, 100mm, 120mm BSA Threaded >121mm Pressfit (with adapter) |

*Bottom brackets not specified may be compatible. Contact CYC MOTOR LTD for more information before making a purchase if your bottom bracket is not listed above.



Parts List

| | |
|---------------------------------------|--|
| Photon Motor Assembly |  |
| SW102 or DS103 Display |  |
| Thumb Throttle |  |
| Magnetic Bluetooth Speed Sensor |  |
| Bottom Bracket Spacers |  |
| (OPTIONAL) Magnetic Brake Sensors |  |
| (OPTIONAL) Controller Extension Wires |  |
| Mounting Support Plate |  |
| Spindle Spacers |  |
| BB92 to BSA adapters |  |



| | |
|--------------------------------------|---|
| <p>Crankarms with crankarm bolts</p> |  |
| <p>Left BB Cup</p> |  |
| <p>Mounting Hanger</p> |  |
| <p>Retaining Lock Ring</p> |  |
| <p>Spindle</p> |  |
| <p>Photon Chainring Set</p> |  |



Dimensions

BSA Threaded 68/73/83mm Version

| | |
|----------|-----------------------|
| A | 96mm |
| B | 128mm |
| C | 150mm / 170mm / 210mm |
| D | 69 mm |
| E | 165mm / 175mm |
| F | 47 mm |
| G | 60.5mm |
| H | 83mm |
| I | 13.3mm |
| J | 54.8mm |
| K | 64.6mm |
| L | 77.8mm |
| M | 88.9mm |
| N | 104.4mm |
| O | 80.1mm |
| P | 95.6mm |
| Q | 30.55mm |
| R | 14mm |
| S | 200mm |

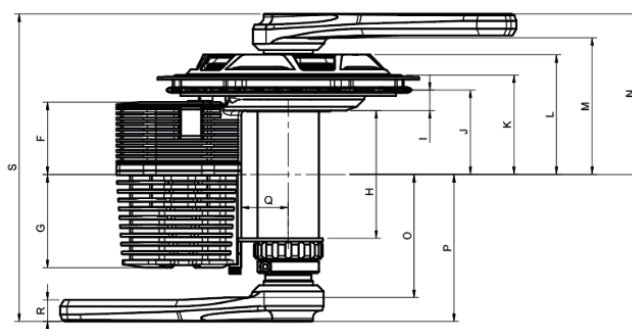
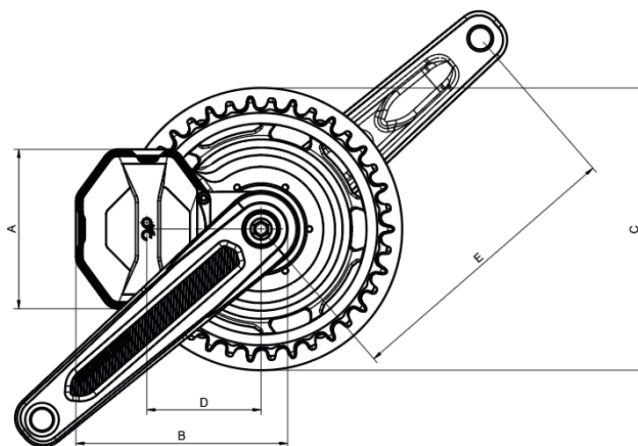



Dimensions

BSA Threaded 100mm Version

| | |
|----------|-----------------------|
| A | 96mm |
| B | 128mm |
| C | 150mm / 170mm / 210mm |
| D | 69mm |
| E | 165mm / 175mm |
| F | 55.5mm |
| G | 52mm |
| H | 100mm |
| I | 13.3mm |
| J | 63.3mm |
| K | 73.1mm |
| L | 86.26mm |
| M | 97.4mm |
| N | 112.9mm |
| O | 91.6mm |
| P | 107.1mm |
| Q | 30.65mm |
| R | 14mm |
| S | 220mm |

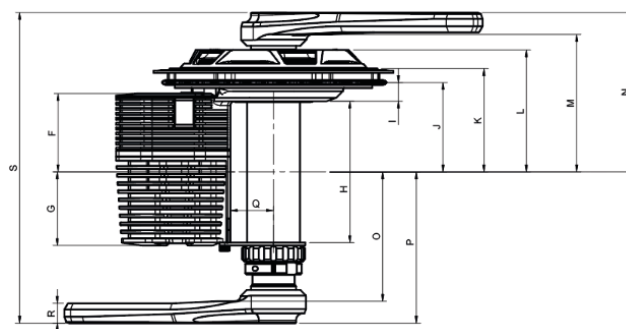
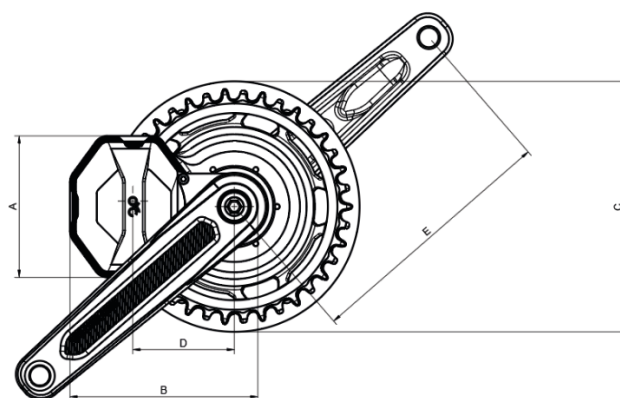



Dimensions

BSA Threaded 120mm Version

| | |
|----------|-----------------------|
| A | 96mm |
| B | 128mm |
| C | 150mm / 170mm / 210mm |
| D | 69mm |
| E | 165mm / 175mm |
| F | 65.5 mm |
| G | 42mm |
| H | 120mm |
| I | 13.3mm |
| J | 73.3mm |
| K | 83.1mm |
| L | 96.26mm |
| M | 110.1mm |
| N | 125.6mm |
| O | 101.6mm |
| P | 107.1mm |
| Q | 30.65mm |
| R | 14mm |
| S | 230mm |

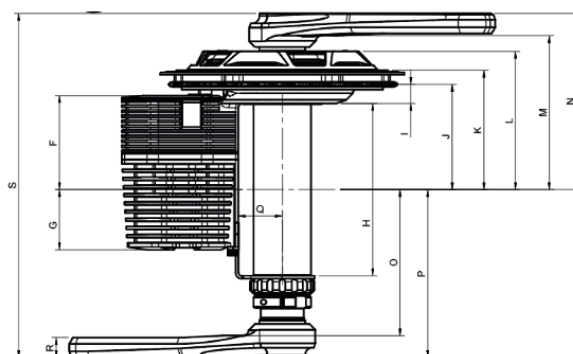
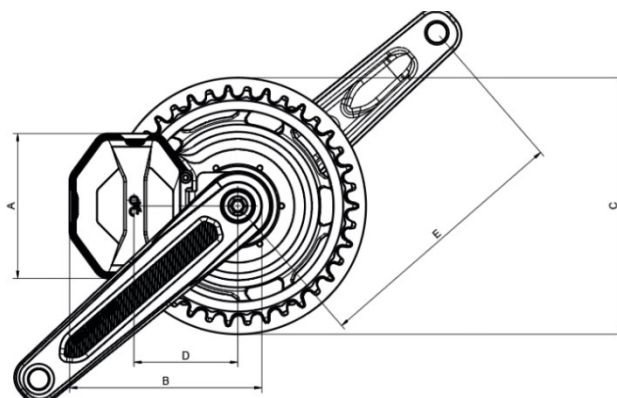



Dimensions

BB92 Version

| | |
|----------|-----------------------|
| A | 96mm |
| B | 128mm |
| C | 150mm / 170mm / 210mm |
| D | 69mm |
| E | 165mm / 175mm |
| F | 52.5mm |
| G | 55mm |
| H | 92mm |
| I | 13.3mm |
| J | 60.3mm |
| K | 70.1mm |
| L | 83.3mm |
| M | 94.4mm |
| N | 109.9mm |
| O | 94.6mm |
| P | 110.1mm |
| Q | 30.55mm |
| R | 14mm |
| S | 220mm |

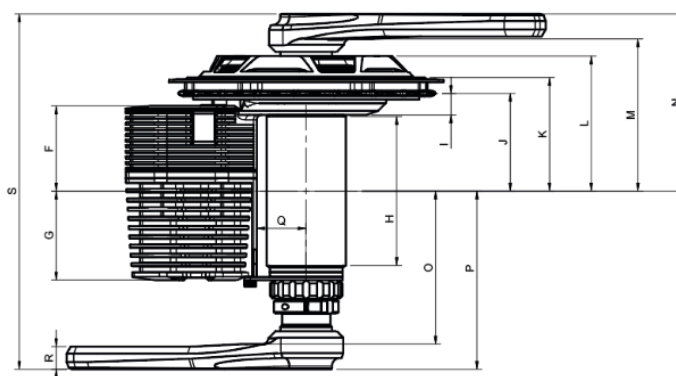
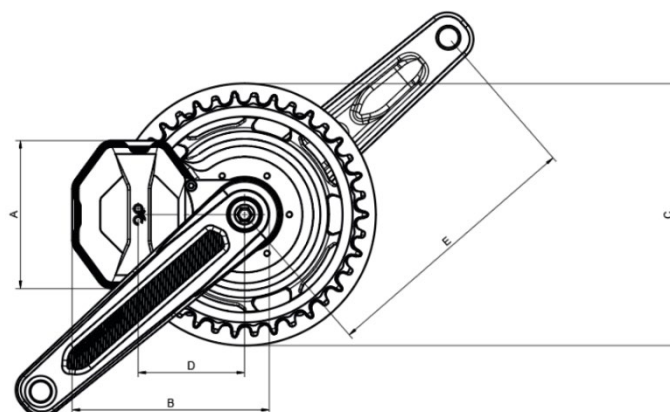



INSTALLATION

Required Tools

| | |
|---|--|
| Hex Keys (3mm & 8mm) |  |
| Adjustable Wrench |  |
| Crank Puller (for disassembly) |  |
| PressFit Bottom Bracket Removal Tools (Only for BB92 version) |  |
| 16 Notch Bottom Bracket Tool |  |



Operating Notice

RIGHT-HAND and LEFT-HAND sides are determined by the bike handle; Right-hand corresponds to the right handle.

Preparing Your Frame

Before you begin, ensure that you have removed the original crankset and bottom bracket from the bicycle frame. This includes any bearings, bottom bracket from the bicycle frame. This includes any bearings, bottom bracket ups, inserts, and/or adapters that might have been fitted. Clean up any grease and/or debris from your frame's bottom bracket shell and wipe off any excess dirt from your frame around the areas where the drive unit and its peripherals will be installed.

Mounting Options

This product can be mounted in any position around the bicycle frame's bottom bracket shell that supports the drivetrain's movement without obstruction. The chainring assembly together with your bicycle chain must be able to move freely and not come into contact with other components or areas on the bicycle frame.

Warning

The motor body must be supported against either the bicycle frame or supporting structures in order to prevent the motor body from movement during use.

Carefully thread in the bottom bracket slightly and insert the spindle to ensure proper alignment. **DO NOT** force threads! Add grease on threads and spindle.



Adjusting the Width of the Bottom Bracket

In order for the CYC kit to fit on various different widths of bottom brackets, there are several spacers that come with the kit. These spacers are designed to provide the bottom brackets with necessary spacing between the motor brackets.

Please note that the spacers can be adjusted to accommodate different chainlines as needed.

The preferred mounting set-ups are shown on the next page for 68mm and 73mm bottom brackets.

Before you begin, ensure that you have removed the original crank set and bottom bracket from your frame. This includes any bearings and/or cups that might have been fitted previously. To install your CYC kit, you will need a clean bottom bracket shell on your frame.

| BB Version | Q Factor | Chainline | Spacer on Left | Spacer on Right | Center Offset |
|------------------|----------|-----------|----------------|-----------------|---------------|
| BSA 68mm | 200 | 50.3 | 5 + 7 | 3 | -0.1 |
| BSA 73mm | 200 | 49.8 | 3 + 7 | 0 | -0.6 |
| BSA 83mm | 200 | 54.8 | 0 | 0 | 4.4 |
| BB92 | 200 | 59.3 | 3 + 3 | 0 | 0.1 |
| BSA 100mm | 220 | 63.3 | 0 | 0 | 2.9 |
| BSA 120mm | 230 | 73.3 | 0 | 0 | 7.4 |

Assembly Instruction

1. Install the chainring assembly to the motor unit.
2. The chainring assembly splines onto the gear of the motor unit.
3. The retaining cap can be threaded on with the provided tool. Please take note of the tightening direction.

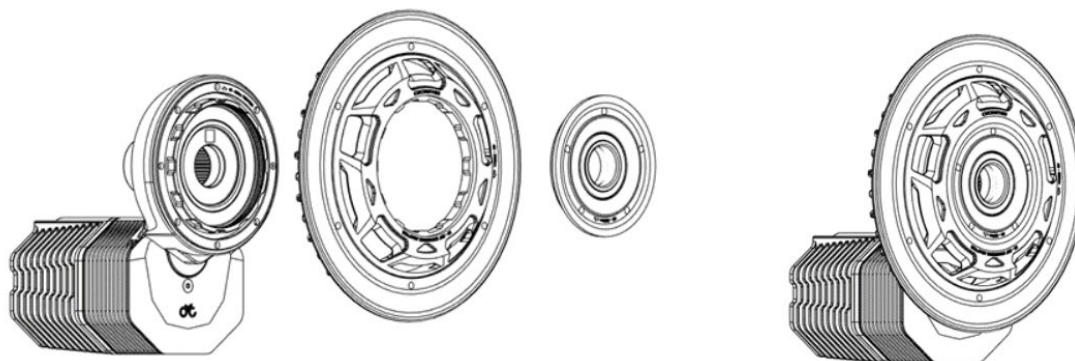

4. Insert the motor so that the back of the motor sits closest to the drive side of the bottom bracket.
5. Ensure that the motor is mounted from the right-hand side of the bicycle frame.

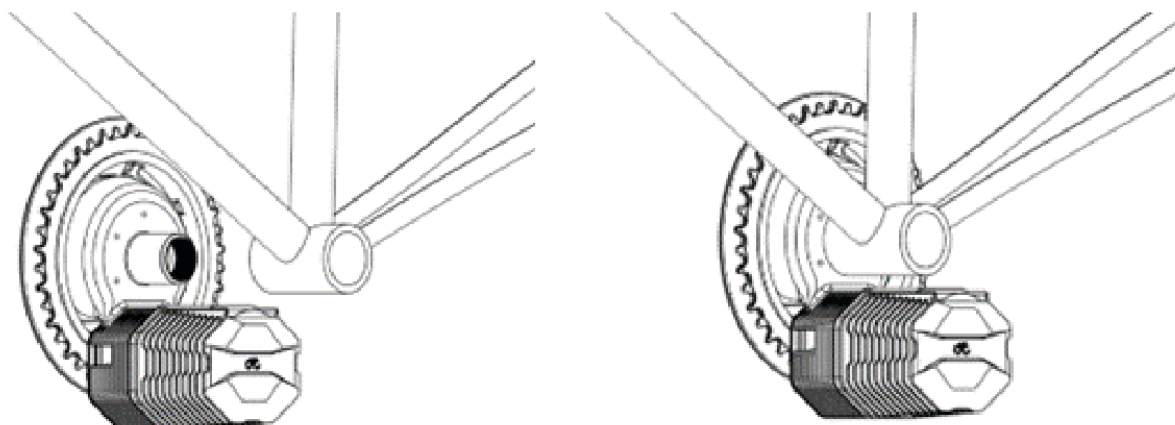

6. Take note of the clearance between the chainstay of the bike and the motor unit. Sometimes the motor unit will need to be spaced out to additionally create space for the chainring and chainstay.

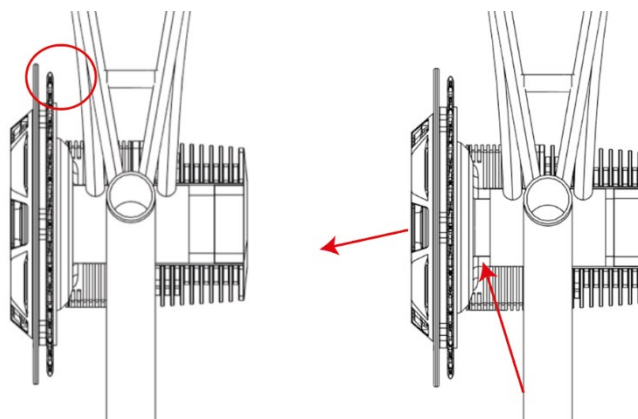



- The Photon motor is designed for an effective BB width of 83mm. Thus, the required length needed for a 68mm or 73mm bottom bracket needs to be taken up by the provided bottom bracket spacers. You can add a 0.5mm spacer if needed to compensate for bike tolerance. Add grease before threading in the BB cup.

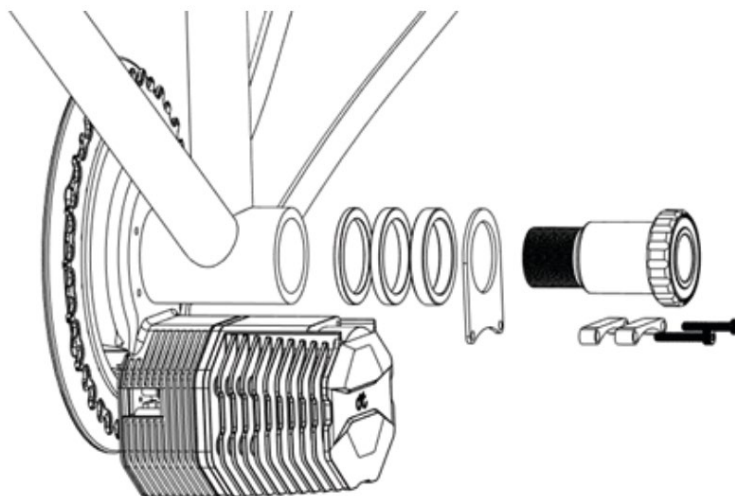

- When inserting the left BB cup with spacers, please ensure that the A-frame support is added to the left BB cup first so that it sits against the tool side of the BB cup. Then place the A-frame in the cutout of the motor housing while inserting the left BB cup into the bottom bracket. Tighten by hand only. If done correctly, the A-frame support should be flush with the cutout of the motor body.

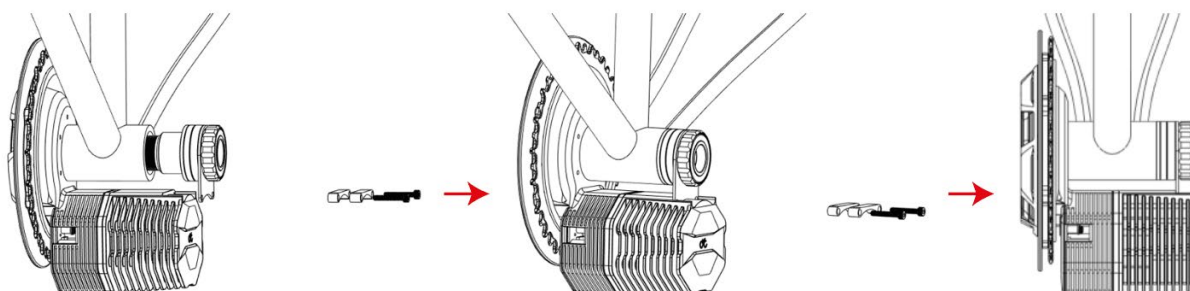

- Place the 8mm & 9mm spacers in the remaining open space of the motor cover and thread the two M4 screws through them and into the body. Securely tighten these screws.

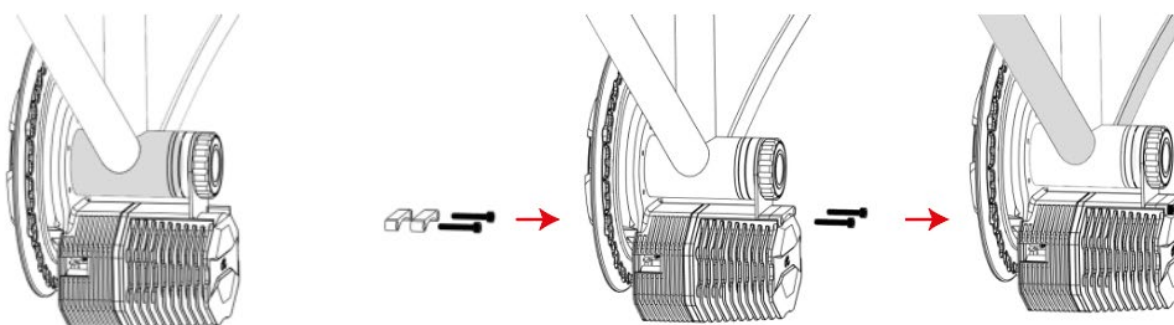

10. Pivot the motor up and securely tighten the BB cup of the motor system. Add the mounting support plate to protect the frame if needed.

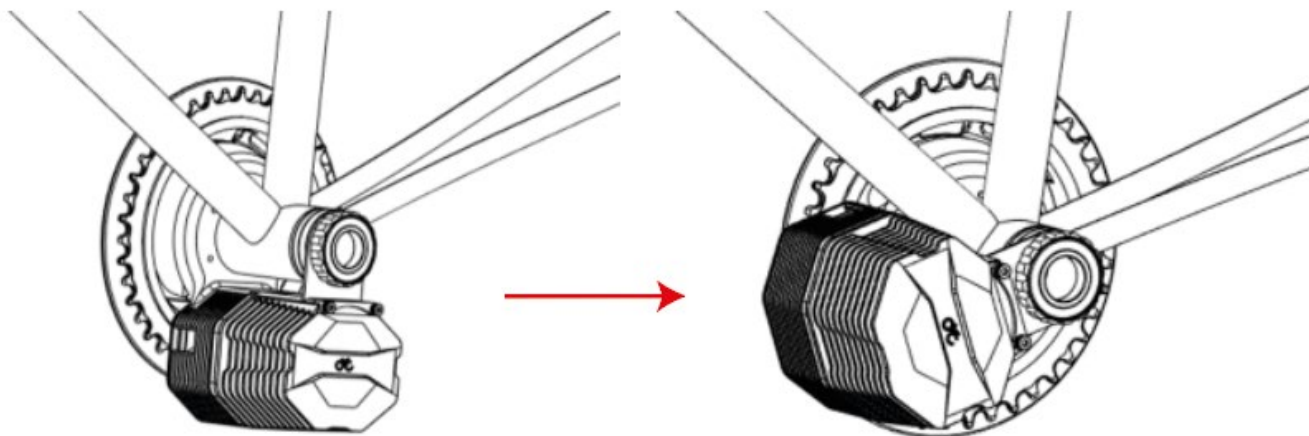

11. Take the spindle and insert it through the motor assembly until the step on the shaft is in contact with the motor. We recommend adding grease on the bearing to have better waterproofing.

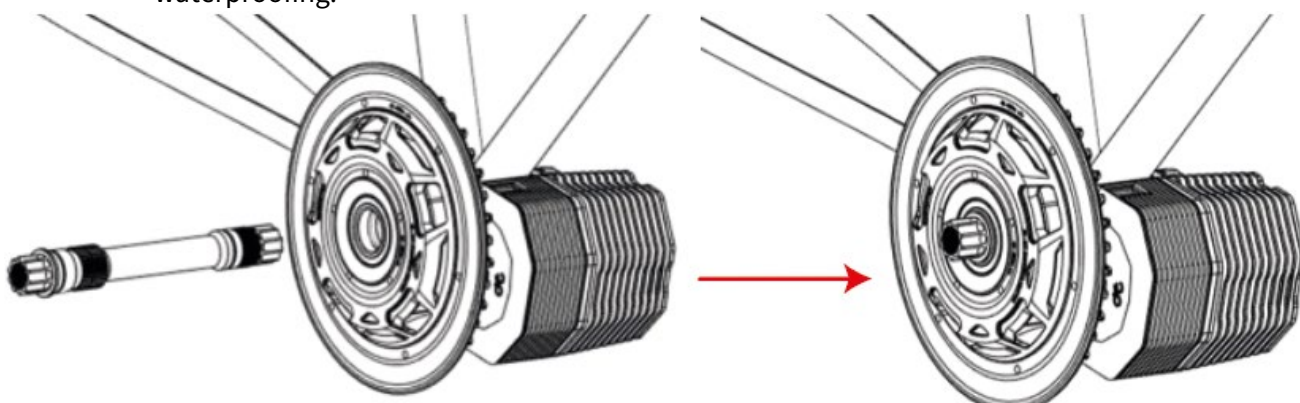

12. Thread the lock ring onto the spindle, with step on the lock ring facing towards the bike. Tighten by hand and then tighten the screw on the lock ring.
13. Ensure that the spindle can rotate freely.

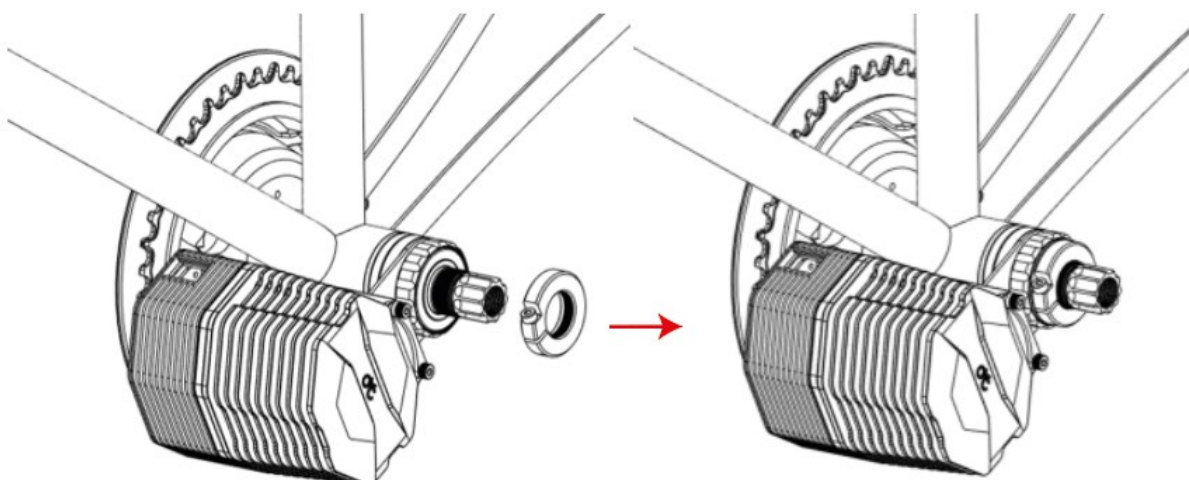



14. Add spindle spacers up to the indicated line. We can provide recommended sizes, but small adjustments are needed due to variances in BB sizes.

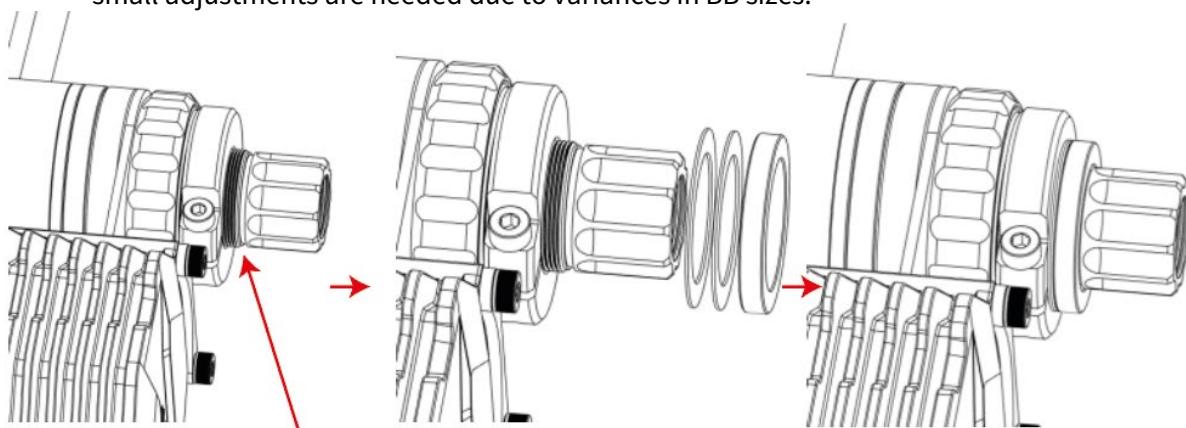

15. Install the crankarms and crankarm bolts and tighten accordingly.

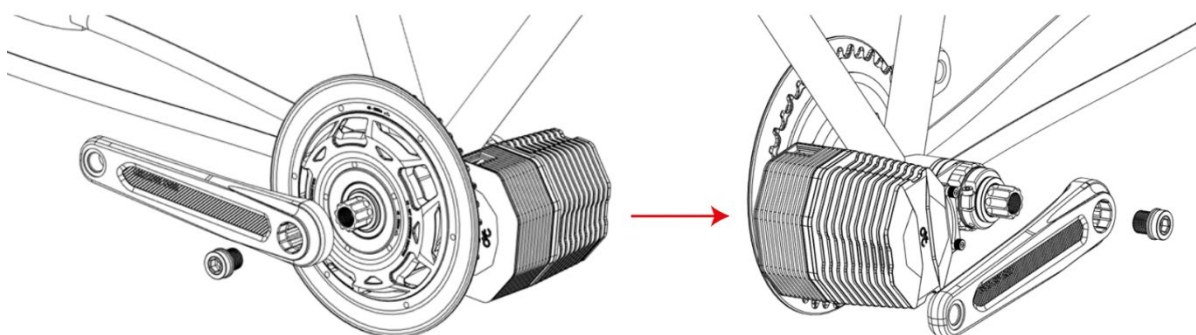

16. When tightening the crankarms, ensure that the cranks touch the step of the spindle of the drive side and the spindle spacers on the non-drive side so that there is no remaining gap.

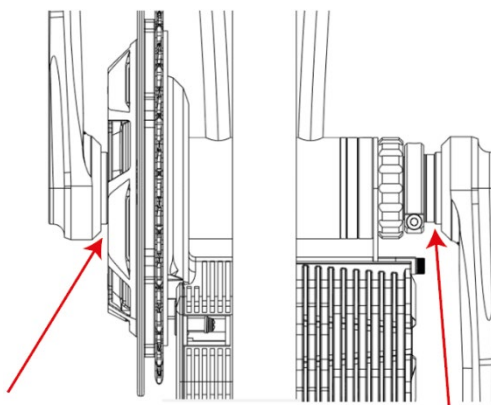

Spacer Information

| BB Version | Q Factor | Chainline | Spacer on Left | Spacer on Right | Centre Offset |
|---------------|----------|-----------|----------------|-----------------|---------------|
| BSA68 | 200 | 50.3 | 5+7 | 3 | -0.1 |
| BSA73 | 200 | 49.8 | 3+7 | 0 | -0.6 |
| BSA83 | 200 | 54.8 | 0 | 0 | 4.4 |
| BB92 | 220 | 59.3 | 3+3 | 0 | 0.1 |
| BSA100 | 220 | 63.3 | 0 | 0 | 2.9 |
| BSA120 | 230 | 73.3 | 0 | 0 | 7.4 |



Wiring & Connection

Connect your controller to the following connectors as per below:

1. Connect the peripheral connector (P1) to the 1-2 or 1-4 wiring harness
2. Connect P2 to the speed sensor

For brake sensors:

Please note if you purchased brake sensors separately, you will need to enable them on the CYC Ride Control app. If you purchased brake sensors from another supplier, please ensure that the connectors match. A pin-layout may be requested at support@cycmotor.com

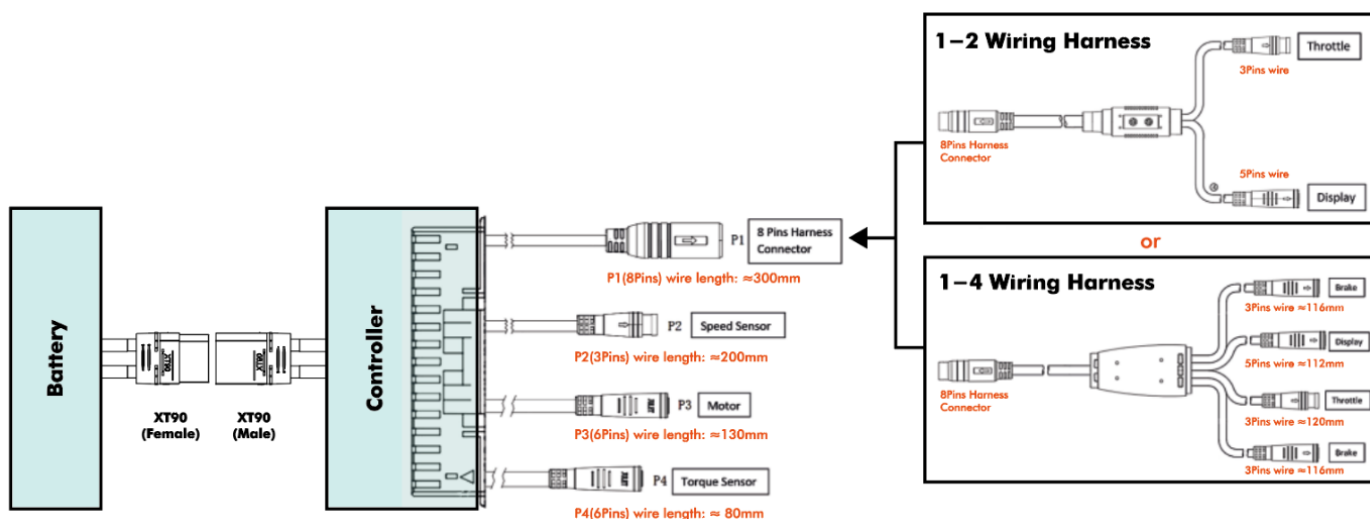



MOBILE APP & DISPLAY

Download the **display** and **mobile app** user manuals from the link below or by scanning the QR code. All materials listed below are freely available for download on our website.

<https://www.cycmotor.com/downloads>

Included in the **downloads** page:

- Instruction Card
- User Manual
- Ride Control App User Guide
- SW102 Display App User Guide
- DS103 Display User Guide
- Speed Sensor Installation Guide
- Brake Sensor Installation Guide
- 1.1 printouts for mounting reference

And much more!





GENERAL MAINTENANCE

You are advised to regularly maintain, clean, and check the status of the bike and motor system as dirt will accumulate throughout the rides and additional strain will be taken by the drivetrain due to the powerful motor system. We recommend that users should inspect the bike and motor condition before and after each ride.

Disconnect all power supplies from the drive unit before starting any work (e.g., inspection, repair of the bike, maintenance work etc.) on the bike, transportation, or storage. Unintentional activation of the drive could lead to serious damage or injury.

Never reach into the chains, gears, or any moving parts while the bike is still in operation.

As the drive unit can get hot after use, be sure to give it some time to cool down before performing any maintenance.

Store the bike in a cool and dry place, sheltered from direct sunlight and potential rain.

Do not attempt to disassemble or modify the drive unit. The drive unit may only be repaired and maintained by qualified experts and only replaced with original spare parts. This will ensure that the safety/warranty of the drive unit is maintained.

The active moving parts (e.g., chain, gear, speed reducer etc.) should be regularly lubricated to maintain desired performance. In case of any abnormal activity, stop using the drive unit immediately and contact your CYC dealer.

Do not attempt to replace the product parts with the parts that have been found at a local bicycle store as the materials used in the drive unit are specifically designed for their purposes.

All bolts, nuts and screws are required to be tightened to the correct torque, if there is anything loose, stay off the bike. Torque specifications for each bolt and nut is provided.



Torque Requirement for Bolts

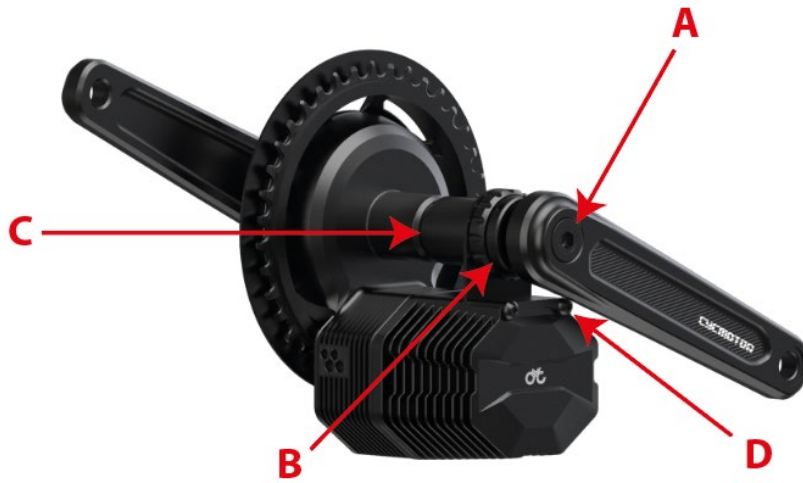

| Listing | Component Name | Torque Requirement |
|----------|-----------------|--------------------|
| A | Crank Arm Bolts | 27 – 32 N.m. |
| B | Lockring | Tighten by hand |
| C | Left BB Cup | 40 – 50 N.m. |
| D | A-Frame Bolts | 5 N.m. |



WARRANTY

This product has a 2-year warranty period. Man-made failures are excluded from warranty. Terms and conditions apply. Please visit www.cycmotor.com/refund-and-return-policy for more information.

For any queries or complaints, please contact us directly at support@cycmotor.com or visit our online store for replacement parts at www.cycmotor.com/shop.

PURCHASES FROM A CYC DEALER

CYC authorized dealers may have different terms and conditions. If you are experiencing any issues with your item/s and did not purchase the kit directly from us, kindly consult the appropriate dealer for assistance.

CONTACT INFORMATION

For customer support, including shipping, quotes, tax, and sales -> support@cycmotor.com

For technical assistance, including build assistance, recommendations, troubleshooting, and product related queries -> technical_support@cycmotor.com.

OFFICE HOURS

Monday to Friday

9AM – 6PM (Hong Kong Time HKT)



DISCLAIMER

The electric bicycle system described in this user manual is designed for converting a bicycle only. It is important to read and understand this manual before using the system.

The manufacturer of this electric bicycle system will not be held liable for any direct, indirect, incidental, or consequential damages that might arise from the use or misuse of this system. Users are solely responsible for their safety while operating their electric bicycles and assume all risks associated with the use of this system.

PRIVACY POLICY

CYC MOTOR LTD strives to provide the best ebike & emtb experiences through our mid-drive electric bike conversion kits, adhering to the highest standards of industry ethics. We encourage you to read our Privacy Policy for more details.

CYC MOTOR LTD developed the CYC MOTOR LTD apps, including the RISTRETTO 303 FS and CYC Motor (BAC) app, as free services. These services are provided by CYC MOTOR LTD at no cost and are designed for use 'as is.' The RISTRETTO 303 FS and CYC Motor (BAC) apps gather location data to facilitate Bluetooth device searching following the ASI controller's protocol. Please note that we do not upload or track your location data.

This page aims to inform visitors about our policies concerning the collection, use, and disclosure of Personal Information for those who decide to use our Service.

By choosing to use our Service, you consent to the collection and use of information in accordance with this policy. The Personal Information we gather is employed for providing and enhancing the Service. We will not use or share your information with anyone except as described in this Privacy Policy.

The terms in this Privacy Policy have the same meanings as in our Terms and Conditions, accessible at CYC MOTOR LTD, unless otherwise specified in this Privacy Policy.

INFORMATION COLLECTION AND USE

To enhance your experience while using our Service, we may need you to provide us with certain personally identifiable information, such as your name (optional), phone number, email address, and location (optional). This information, once collected, will be retained, and utilized as outlined in this privacy policy. Please be aware that our app uses third-party services that may collect information used to identify you.



Please visit www.cycmotor.com/privacy-policy for more detailed information.